

**2021 NDIA GROUND VEHICLE SYSTEMS ENGINEERING AND TECHNOLOGY  
SYMPOSIUM  
ADDITIVE MANUFACTURING TECHNICAL SESSION  
AUGUST 10-12, 2021 - NOVI, MICHIGAN**

**UTILIZING ADDITIVE MANUFACTURING TO ENABLE LOW-COST,  
RAPID FORMING OF HIGH TEMPERATURE LIGHTWEIGHT GROUND  
VEHICLE STRUCTURES**

**David Erb<sup>1</sup>, Benjamin Dwyer<sup>1</sup>, Jonathan Roy<sup>1</sup>, William Yori<sup>1</sup>,  
Roberto A. Lopez-Anido<sup>1</sup>, Andrew Smail<sup>2</sup>, Robert Hart<sup>2</sup>**

<sup>1</sup>Advanced Structures and Composites Center, University of Maine

<sup>2</sup>US Army DEVCOM Ground Vehicle System Center

**ABSTRACT**

*Barriers to the introduction of composite materials for ground vehicle applications include material property selection and cost effective material processing. Advancements in processing of thermoplastic composites for use in applications for semi structural and structural applications have created opportunities in “Out of Autoclave” processing utilizing preconsolidated unidirectional reinforced tapes. Traditional tooling for the bending formation of high temperature reinforced structural thermoplastic laminates typically involves matched metal tooling consisting of steel or aluminum and are costly and heavy. In this research, a comparative analysis was performed to evaluate the use of a large scale 3D printed forming tool in comparison to a traditional metallic mold. Material processing considerations included the development of a technique for localized laminate heating to achieve optimized energy input in the forming process. Considerations in tooling development included the comparison of the overall cost, lead times and embodied energy. This comparison also included the design and simulation of process engineering to form the parts in both cases.*

**Citation:** D. Erb, B. Dwyer, J. Roy, W. Yori, R.A. Lopez-Anido, A. Smail, R. Hart, “Utilizing Additive Manufacturing To Enable Low-Cost, Rapid Forming Of High Temperature Lightweight Ground Vehicle Structures”, In *Proceedings of the Ground Vehicle Systems Engineering and Technology Symposium (GVSETS)*, NDIA, Novi, MI, Aug. 10-12, 2021.

## **1. INTRODUCTION**

The barriers to the introduction of light weight composite material systems for

ground vehicle applications include the overall higher cost of composite based material systems along with the high cost of matched metal tooling that is traditionally used to form complex composite material structural shapes. In low volume production based environments such as the military

ground vehicle domain the high cost of matched metal tooling can add significant expense to the overall targeted component cost making the overall benefit of these lightweight material solutions non-cost effective in this risk adverse environment. The introduction of additive manufactured (a.k.a., AM or 3D printed) tooling helps to address this issue by maintaining the processing advantages of localized heating and compression forming to achieve higher fiber volume content over alternative lower cost production processes such as VARTM/RTM at a significantly reduced tooling cost.

The University of Maine's Advanced Structures and Composites Center (ASCC) began a development program to reduce vehicle weight, while remaining cost-neutral, for a Multipurpose Wheeled Vehicle replacing an existing aluminum component with fiber-reinforced thermoplastic matrix composite of equivalent geometry.



Figure 1.0 Carbon/PPS composite vehicle component fastened to vehicle end cap and pillar components, ready for assembly to vehicle.

As shown in Figure 1.0 the vehicle component consists of side and top surfaces which are nearly at a right (90 degree) angle to one another. A narrow surface at approximately 45 degrees to the top and side surfaces is defined by two linear bends that run the length of the structure. These two long bends are what we refer to as the “center bends”, since they are located effectively in

the center of the laminate blank's width that forms the component.

Challenges to the introduction of composite materials for ground vehicle applications include material property selection, cost-effective manufacturing as well as flame/smoke/toxicity (FST) properties. This paper presents a method for leveraging additive manufacturing to address each of these barriers by reducing the lead time and cost of producing lightweight FST-rated thermoplastic composite structures for military ground vehicle applications. A significant outcome from this program was that the University of Maine in cooperation with the US Army Ground Vehicle Systems Command demonstrated that low-cost tooling, with short manufacturing lead-times, and commensurate manufacturing process, enabled the forming of a high-temperature thermoplastic polymer (PPS) composite with a reinforced low-temperature, AM polymer (ABS) mold.

## 2. MATERIAL SELECTION

Fiber and matrix material selection was driven by several - sometimes conflicting - factors, which included stiffness, matrix glass transition temperature ( $T_g$ ), and laminate heat deflection temperature (HDT) largely based on the application environmental use temperature. Fire, Smoke, and Toxicity (FST), cost, and processing temperature were also factors considered. Our team compared properties of six different commercial grades of preconsolidated unidirectional reinforced thermoplastic tape materials for the composite layups. The screening included four standard ASTM tests which allowed material comparison and downselection for the application. The six candidate materials included GF/PETG, GF/PP, GF/PC, GF/PET, GF/PPS and CF/PPS. Initial screening was completed with FST being the primary driver due to material's use in a

vehicle application. The ASTM vertical burn test (D3801) was considered one of the quickest methods to screen for flammability and propensity of the materials to self-extinguish.

Through this testing, it was determined that fiber reinforced PPS was the least flammable of the materials tested and was the only material to score a flammability rating of V-0. Glass fiber reinforced PC was the second least flammable option, scoring a flammability rating of V-1. Glass fiber reinforced PP performed similarly to the GF/PC but tended to burn for longer before self-extinguishing, resulting in it exceeding the V-2 flammability rating and receiving a NO-GO. Glass fiber reinforced PET performed slightly worse than the GF/PP and in one instance was unable to self-extinguish and burned completely. GF/PET exceeded the V-2 flammability rating and received a NO-GO. Glass fiber reinforced PETG performed the worst of the materials tested burning completely in all cases. GF/PETG exceeded the V-2 flammability rating and received a NO-GO. Of the materials tested, GF/PPS and CF/PPS performed the best. Table 1.0 shows the result of this testing.

Material	V - Classification
GF/PETG	NO-GO
GF/PP	NO-GO
GF/PC	V-1
GF/PET	NO-GO
GF/PPS	V-0
CF/PPS	V-0

Table 1.0 ASTM D3801 vertical burn (flame spread) test results.

In addition to the ASTM D3801 vertical burn screening, four additional tests were utilized in down-selecting materials for the application including ASTM E662, Standard Test Method for Specific Optical Density of Smoke Generated by Solid Materials. ASTM

1354, Standard Test Method for Heat and Visible Smoke Release Rates for Materials and Products Using an Oxygen Consumption Calorimeter and ASTM E162, Standard Test Method for Surface Flammability of materials using a Radiant Heat Energy Source. Table 2.0 below shows the results of this testing with suggested Pass Outcome Ranges for individual material evaluation being provided by GVSC.

Test Title	ASTM	SAMPLE ID															
		PPS/CF			PPS/GF			PETG/GF			PP/GF(FR)			PET/GF			PC/GF
Vertical Burn (V-0 Rating)	D3801	P	P	P	P	P	P	F	F	F	F	F	F	F	F	F	
Vertical Burn (V-1 Rating)	D3801	P	P	P	P	P	P	F	F	F	F	F	F	P	P	P	
Vertical Burn (V-2 Rating)	D3801	P	P	P	P	P	P	F	F	F	F	F	F	P	P	P	
Suggested GVSC FST Std.		L1	L2	L3	L1	L2	L3	L1	L2	L3	L1	L2	L3	L1	L2	L3	
Smoke Density Surface	E662	P	P	P	P	P	P	P	P	P	P	P	P	P	P	P	
Flamability Heat and Visible Smoke	E162	P	P	P	P	P	P	P	P	P	P	P	P	P	P	P	
	1354	P	P	P	P	P	P	F	F	F	F	F	F	P	P	P	

Table 2.0 ASTM FST screening test results. F = fail; P = pass.

How well each of the candidate thermoplastic polymers would retain its structural properties under elevated temperature environments was a key consideration. Table 3.0 shows the glass transition and melting temperatures for each of the candidate polymers.

Thermoplastic Resin	Tg	Melting
PP		160°C (320°F)
PET	80°C (176°F)	230°C (446°F)
PETG	88°C (190°F)	243°C (470°F)
PC	153°C (307°F)	-
PPS	90°C (194°F)	280°C (536°F)

Table 3.0 Glass transition temperature (Tg) and melt temperature of the thermoplastic polymer candidates.

A requirement for replacing the aluminum component with a composite component was to provide equal or less deflection under loads which include vehicle

bending and twisting, eccentric hinge loads, and personnel standing on unsupported edges. Static structural finite element analysis (FEA) was performed using Siemens Simcenter 3D software (Siemens Digital Industries Software) to design the laminate and predict its deformation and strength.

PET, PETG, and PP thermoplastic resin candidates were eliminated prior to FEA based on their low glass transition temperature and unacceptable FST test results. Material properties used in the FE analyses were reduced to account for worst-case notched (open-hole compression and tension, D6484 and D5766) and elevated temperature-wet (ETW) conditioning.

In consideration of FST results, thermal-mechanical properties and vehicle environmental requirements as well as FEA-predicted composite part deflections compared to the baseline aluminum part, only carbon-fiber reinforced PPS was deemed sufficient to manufacture the test articles.

With this in mind, our team was now challenged with the high temperature processing considerations of PPS resin, which is formed at temperatures exceeding 315 Deg C (600 Deg F).

### 3. METAL TOOLING DEVELOPMENT

Metal offers numerous advantages over AM molds, such as surface hardness and finish, higher thermal conductivity, robustness in a production environment as well as multiple part cycles and handling, and ability to be machined to precise tolerances for multiple parts' assembly fitment.

This program's metallic mold design went through several iterations to reduce cost and lead-time. Initial mold design, shown in Figure 2.0, included features to both form the component shape (i.e., bends) then serve as a trim and drill fixture. This is an ideal mold, especially for programs where numerous

components are to be fabricated. However, this approach would have exceeded the project's budget and lead time. The final, simplified mold shown in Figure 3.0 included geometry to form the two center bends only.

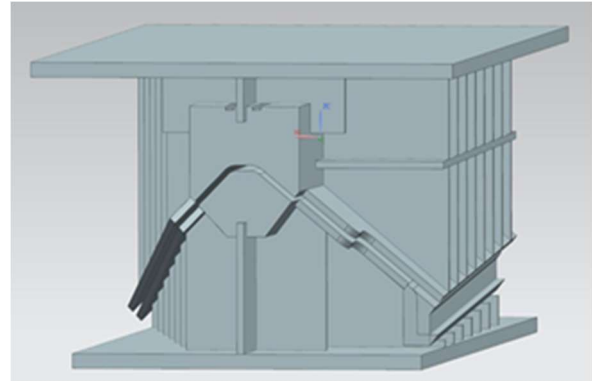

Figure 2.0 Initial mold design including all three bends (two center and one edge), and built-in trimming and drilling capability.

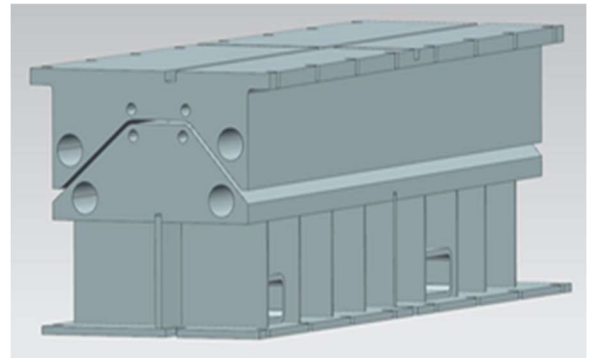

Figure 3.0 Final mold design encompassing only bending of the two "center" radii capability.

Due to the nature of the way traditional metallic molds are fabricated, the raw stock needed to be acquired, rough machined, precision gun drilled for the heating and cooling components, then final machined. The gun drilling of the heating and cooling channels was performed independently from the mold machine shop. Thus, the molds were shipped multiple times through the fabrication process, increasing cost and lead-time. A metallic mold could have been designed without inherent heating and cooling, and would be used analogous to the

AM mold. However, one advantage of metal tooling is the ability to directly heat the mold for additional processing control.

Figure 4.0 shows the fabricated metallic mold design mounted in a thermoforming press with a pre-trimmed flat laminate loaded and ready for processing.



Figure 4.0 Fabricated metallic mold set. Plug mold is mounted to the press' bottom platen. Cavity mold is mounted to the press' upper platen.

#### 4. AM TOOLING DEVELOPMENT

In this program, AM tooling was studied in part due to a short deadline encountered for delivery of the composite demonstration component for the Army's component testing schedule. At the time the purchase order for metallic tooling was placed, the delivery time was uncertain due to industry delays caused by the global pandemic of Covid-19. Considering this potential delay, a risk mitigation plan was developed that included parallel-path fabrication of a metallic mold and a low-cost, short lead-time compression mold set utilizing Additive Manufacturing. This approach offered an opportunity to compare metrics of the two mold approaches such as lead time, cost and energy

consumption. Figure 5.0 shows multiple AM mold components being manufactured in one single pass. Figure 6.0 shows a completed compression Mold Set.

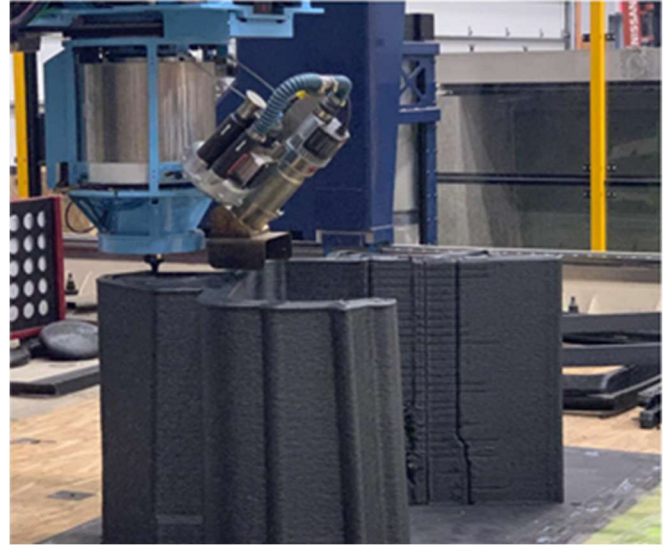

Figure 5.0 Two Large Scale AM molds being printed in one file then separated



Figure 6.0. Complete AM ABS/Sheet metal Clad, Compression Mold Set.

A major technical innovation for this program which allowed the AM molds to be successfully used was the design of precision formed sheet metal cladding placed on the AM mold surfaces. Higher temperature AM polymers are available which could preclude the need for sheet metal cladding, however they are more costly than ABS and were not available within the time needed to remain on

schedule. ABS served as the scaffold for support in the compression forming process while sheet metal cladding allowed faster processing times due to its high thermal conductivity also serving as a heatsink. Figure 6.0 shows the sheet metal clad AM mold mounted in the Thermoforming Press.



Figure 6.0 AM mold set in press. Sheet Metal cladding is clearly visible on the plug mold.

By utilizing the metal cladding process, more readily available, lower performance AM polymers were selected which simplified the printing process and reduced cost and lead times. Even with high-temperature AM polymers, it is possible that without the thermal break and heatsink provided by the sheet metal cladding that multiple cycles of heat released from the hot laminate could soften or distort an unclad AM polymer mold. With sheet metal cladding multiple part forming cycles were completed without any obvious signs of mold degradation.

The vehicle component parts that were formed using the AM molds were ideal candidates for this mold technology (i.e., 3D printed mold with sheet metal cladding). The parts did not have compound curvature i.e., all of the forming was based on straight lines.

If the parts had different geometry, such as a dish shape it may have precluded the ability to precisely form sheet metal cladding. There are AM technologies for metal printing, which may enable these types of part geometry, but more work is required to understand if these technologies can produce low-cost tooling.

## 5. MOLD COMPARISON

A consideration in the comparison of the two mold manufacturing processes is the costs of metal machining (i.e., subtractive manufactured). Metallic molds are based on fully mature technology and in contrast, AM mold technology is in its infancy and still largely R&D for the types of component materials and processes utilized in this program. It is expected that as this large scale AM mold manufacturing technology evolves that the cost will decrease compared to machined metallic molds.

A further consideration in this comparison is that this AM mold design was not optimized to minimize materials under part processing loads. Stress analysis of the mold structure using FEA would have been required to determine the minimum required mold wall thickness. In this case the team erred on the side of caution by using extra print material to ensure no failure of the mold would occur under forming pressures. It is expected that analysis would predict that the AM molds' mass, cost, and lead-time could be reduced from what is reported. Table 4.0 shows a comparison of the cost, fabrication time, and weight of both of the metallic and AM (3D printed) mold sets.

Mold Comparison (Left and Right Side Mold Sets)			
	Cost	Delivery Time	Weight (Mass)
<b>Metallic</b>	\$77K	Eight (8) weeks	2,208 lb (1,002 kg)
<b>AM</b>	\$50K	Three (3) weeks	1,788 lb (811 kg)

Table 4.0 Comparison of cost, fabrication time, and weight of metallic versus AM molds.

When comparing the manufacturing steps of a typical metallic mold it's clear that numerous steps can be saved using an AM process. Metallic molds require rough and finished machining of numerous individual components as well as welding and then a final component assembly.

The AM process combines many of the steps used in the metallic manufacturing process by manufacturing many components concurrently. Figure 7.0 shows a flow chart comparing the primary fabrication steps for each mold type.

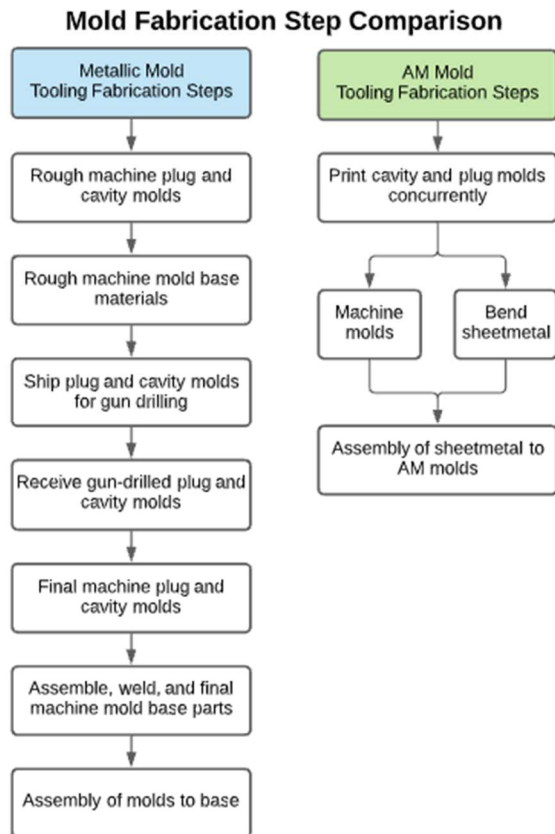

Figure 7.0 Comparison of primary mold fabrication steps for (subtractive) metallic molds and polymer AM molds. Significantly less number of manufacturing steps are required for the AM molds which is part of their short lead-time compared to the metallic molds.

## 6. PRODUCTION METHOD

Manufacturing of the composite component whether using the metallic or AM molds, begins by laying up preconsolidated unidirectional thermoplastic tapes into an unconsolidated, but precisely oriented, stack of plies using an automated tape layup (ATL) system. The system, operated at the University of Maine's Advanced Structures and Composites Center is known as Rapid Efficient Layup (RELAY) and is shown in figure 8.0 below.



Figure 8.0 Dieffenbacher-FiberForge RELAY system located at the University of Maine

The unconsolidated preforms are then heated and pressed into consolidated flat blanks at 310°C (590°F) and estimated pressure applied of approximately 400 psi. Due to tight thickness tolerances required by the end use component, the laminate blanks were pressed to stops to maintain the required thickness tolerance. After allowing the blank to cool it was then trimmed to near net shape using a CNC waterjet cutter.

To form a composite part on the AM mold a pre-trimmed laminate blank was suspended from the upper press platen approximately three inches above the plug mold top surface. Insulation board was placed between the heaters and the blank to isolate the AM mold from being heated during the blank-heating process. Long, narrow heaters were installed

on a sliding carriage system above and below the two center bends. Figure 9,0 shows a rendering of the carriage system designed. At the start of the process, the carriage with heaters is placed so that heaters are located directly above and below the two center bends. When the laminate's bends are heated to the desired forming temperature of 321°C (610°F), the carriage is quickly withdrawn, the suspended locally-heated laminate blank is then quickly lowered onto the plug mold, the upper press platen with cavity mold is rapidly closed onto the laminate and over the plug mold with 200 psi pressure applied to the part. The part is left under pressure to cool for two minutes and then the press is opened.

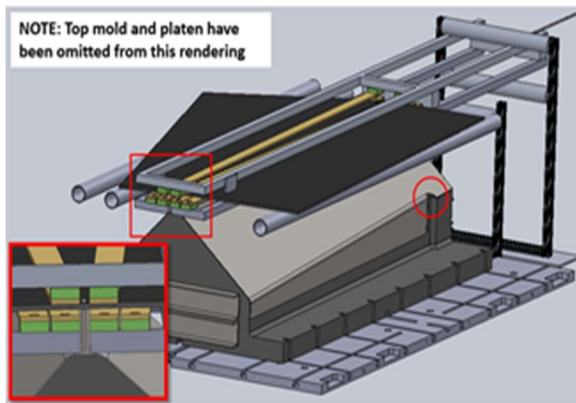

Figure 9.0 AM Mold laminate blank localized heater shuttle carriage.

To form a composite part on the metallic mold, the same pre-trimmed laminate blank used for the AM mold is now placed directly onto the (room temperature) metal plug mold's part surface. Heaters installed in the metal mold heat the laminate blank at the center bends to the desired forming temperature of 321°C (610°F). The upper press platen with metal cavity mold is then quickly closed onto the laminate and metal plug and pressure is applied to the part. The part is left under pressure until sufficiently cooled and then the press is opened.

The primary processing difference between the AM mold and the metal mold, is that the metal plug mold heats the laminate blank to facilitate forming, while for the AM mold the laminate blank is heated locally then placed onto the (room temperature) mold to cool. Energy requirements and cycle times between the two mold processes are shown in Table 5.0.

	Cycle Time (hours)	Power/Cycle (kiloWatt)	Energy/Cycle (MegaJoule)
<b>Metallic Mold</b>	2.5	17.1	154
<b>AM Mold</b>	2	4.0	29

Table 5.0 Cycle time and energy consumption of mold types.

## 7. RESULTS AND CONCLUSIONS

Low cost additively manufactured (AM) tooling with sheet metal modification was introduced. Material selection methodologies for a specific component requirement was discussed and compared against other candidate materials. The forming of a composite material was studied in a comparison utilizing low cost AM tooling and traditional Metallic tooling with manufacturing efficiencies shown in numerous areas including lead-times and cost as well as production efficiencies in faster cycle times and lower overall energy consumption.

The University of Maine with its partners at the US ARMY'S Ground Vehicle Systems Command were able to successfully fabricate high-temperature composite demonstration components on time, which was critical to program success.

In conclusion, the feasibility of using polymer extrusion additive manufacturing for low-cost stamp thermoforming tooling for high temperature thermoplastic composite vehicle parts was demonstrated.



## 8. REFERENCES

- [1] Natassia L. Batista a, b, \*, Mirabel C. Rezende c, Edson C. Botelho b, “Effect of crystallinity on CF/PPS performance under weather exposure: Moisture, salt fog and UV radiation”
- a) Department of Mechanical Engineering, McGill University, 817 Sherbrook Street West, Montreal, QC H3A 0C3, Canada
- b) Department of Materials and Technology, UNESP, Av. Ariberto Pereira da Cunha, 333, Guaratingueta, SP, Brazil
- c) Institute of Science and Technology, UNIFESP, R. Talim, 330, Sao Jose dos Campos, SP, Brazil